

Lift and Slide

ALL WOOD

Lift-and-slide wooden window with lamellar construction

WWW.PBFINESTRE.IT



SECTIONS

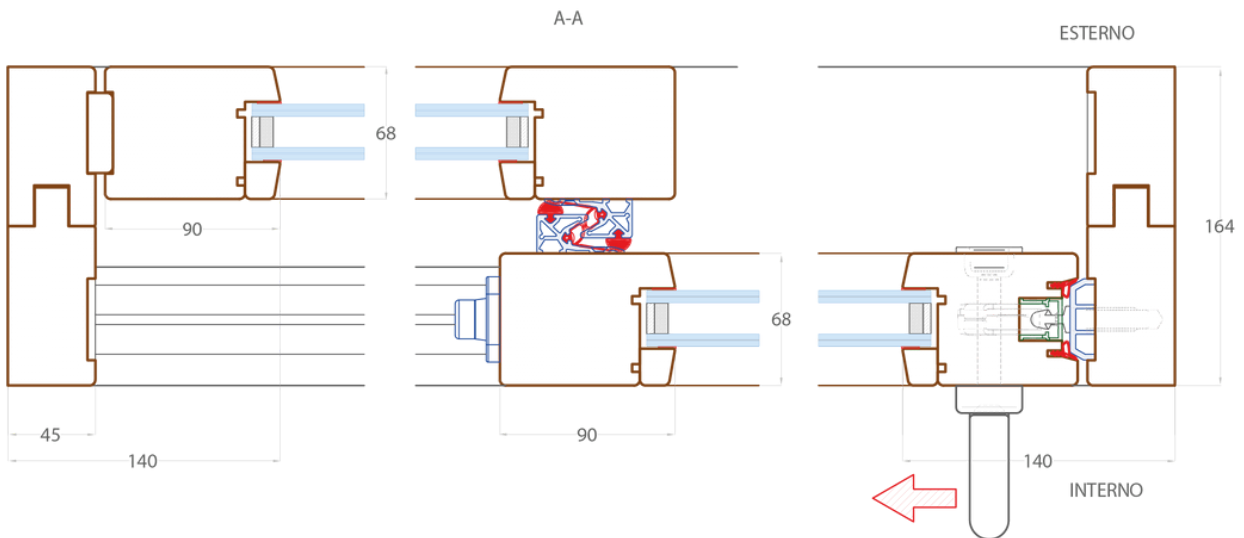

THICKNESS

68mm

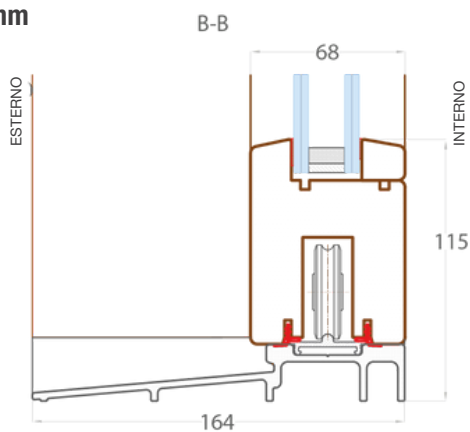

78mm

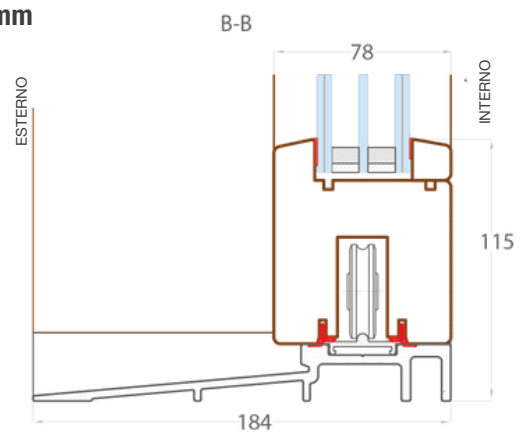

FEATURES



LAMINATED WOOD

Laminated wood is the only material that can guarantee durability, eco-sustainability, resistance, and stability over time, in addition to the possibility of renewing and keeping the product looking new over time.



COLOMBO DESIGN HANDLE HS

Robortquattro HS handle by Colombo Design, standard model in satin chrome brass (other models available upon request) with a 10-year warranty on the finish and external shell.



ENERGY GLASS INSULATING UNIT®

Insulating glass unit with black warm-edge spacer and Planitherm Infinity coating by Saint Gobain, low-emissivity, and selective (Ug: 1.0 W/m²K for single glazing and Ug: up to 0.5 W/m²K for double glazing).



STRUCTURAL SEALING OF INSULATING GLAZING

Structural sealing and bonding of the insulating glazing through 3M double-sided tape, ensuring maximum adhesion of the insulating unit and sealing against infiltrations, maximum resistance against burglary attempts, and structural stability of the doors.



GASKETS

Two black silicone thermal-acoustic seals for the doors, made of durable and heat-resistant materials: not only do they ensure better sealing over time, but they also provide smoother operation by significantly reducing the required pushing force and minimizing noise during opening and closing.



WOOD PAINTING

Treatment carried out with ecological water-based products to eliminate solvent emissions in the air and environment. Process executed through two impregnating and intermediate coats using float coating and a spray finishing cycle. RAL-colored products receive an additional finishing coat.

As wood is a natural material, any chromatic differences in the product are not considered defects but are justified by the different behavior of wood species topaints in staining cycles.



HINGES

Mechanism for a single leaf with a maximum weight of 400 kg, featuring a sliding carriage with two rollers and an additional carriage for interlocking connecting rods. Sliding rollers made with plastic-coated roller bearings. Fiberglass threshold (available in the version with low sliding track) and bumper stops. Central sealing strip made of PVC. Resistance class up to RC2



WARRANTIES

Thanks to the performance qualities and reliability of our windows, we have obtained prestigious certifications from international institutes and offer a 10-year warranty on our products and a 10-year warranty on the painting, according to the terms and conditions of PBFinestre.

TECHNICAL DATA

Air Permeability Resistance Class *

(according to the UNI EN 1026 – 2001 test standard and the UNI EN 12207 – 2000 classification standard)

Class 4

Indicates how much the fixture is permeable to air passing through it at a pressure of 600 Pa, which corresponds to a wind speed of 115 km/h.

Water Tightness Resistance Class *

(according to the UNI EN 1027 – 2001 test standard and the UNI EN 12208 – 2000 classification standard)

Class E750

Indicates the fixture's ability not to be penetrated by water under a pressure of 750 Pascal.

Wind Load Resistance Class*

(according to the UNI EN 12211 – 2001 test standard and the UNI EN 12210 – 2000 classification standard)

up to class C3

Indicates the fixture's ability to resist the wind pressure at a specific speed

Acoustic Reduction Certification **

up to 40 dB

(with glass 44.1 stadiap silence Planitherm Infinity+16 argon gas +33.1 stadiap protect)

Thermal Performance Certifications **

Achievable Uw values:

in the version with a thickness of 68mm **1.2 W/m²K**

in the version with a thickness of 78mm **0.9 W/m²K**

Solar Factor: **G=0,35**

Declaration of European Conformity



CE Mark

Products conforming to the European standard EN 14351-1. All our windows are CE marked, according to the law, to ensure maximum peace of mind and security in your home.

*Only in the presence of a fiberglass threshold or high track as per certifications in our possession issued by the ROSENHEIM Institute

**Only in the presence of a fiberglass threshold or high track as per certifications issued by the GIORDANO Institute



Descriptions are not binding. The company reserves the right to make any necessary modifications. PB FINESTRE WINDOWS AND DOORS is a trademark owned by IWDT SRL a socio unico. All rights reserved.

PBFINESTRE

IWDT Srl a socio unico - 61038 Terre Roveresche (PU) Loc. Barchi - Via Ridolfina, sn Tel. +39 0721.728545 - info@pbfinestre.it